

KT6DCC - 038 - 022 - 008 - 1 R 00 - A 1 - 00 *

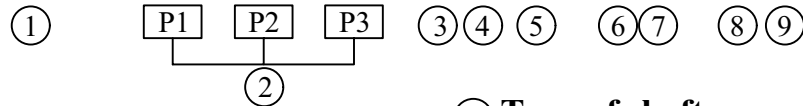

① Series

② Cam ring for " P1 "

Volumetric displacement (cm³/rev)

014=47.6	035=111.0
017=58.2	038=120.3
020=66.0	042=136.0
024=79.5	045=145.7
028=89.7	050=158.0
031=98.3	061=190.5

Cam ring for " P2 " & " P3 "

003=10.8	017=58.3
005=17.2	020=63.8
006=21.3	022=70.3
008=26.4	025=79.3
010=34.1	028=88.8
012=37.1	031=100.0
014=46.0	

③ Type of shaft

- 1 - Keyed (no SAE)
- 2 - Keyed (SAE CC)
- 3 - Splined (SAE C)
- 4 - Splined (SAE CC)

④ Direction of rotation(view on shaft end)

- R=clockwise
- L=counter-clockwise

⑤ Porting combination

00-standard

⑥ Design letter

⑦ Seal class

- 1-S1 (for mineral oil)
- 4-S4 (for fire resistant fluids)
- 5-S5 (for mineral oil and fire resistant fluids)

⑧ Mounting W/connection variables

	Unc		Metric	
	00	01	M0	M1
P3	1"	3/4"	1"	3/4"

⑨ Modifications

HYDROMECHANICAL POWER LOSS (TYPICAL)

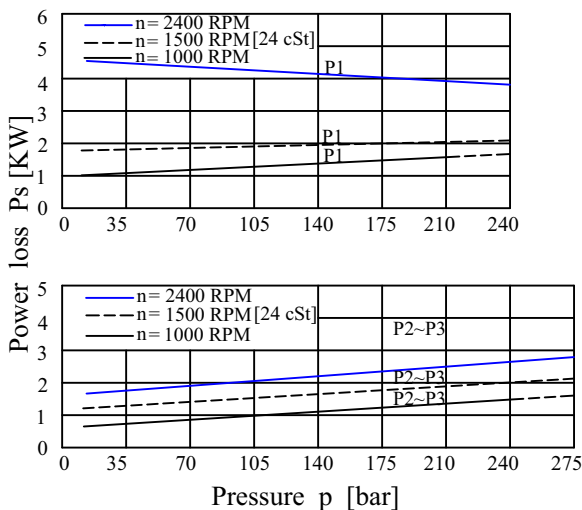

Total hydromechanical power loss is the sum of each section at its operating conditions.

INTERNAL LEAKAGE (TYPICAL)

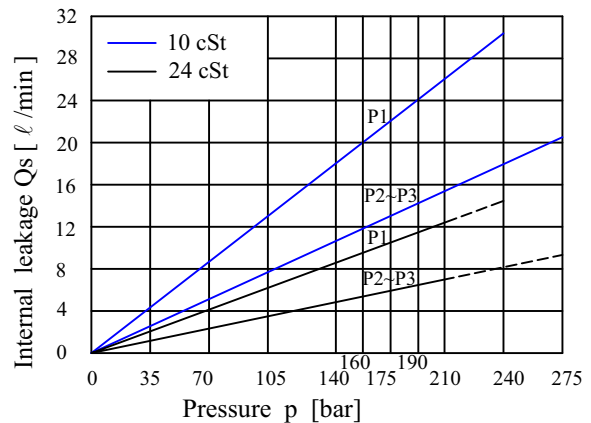

PERMISSIBLE RADIAL LOAD

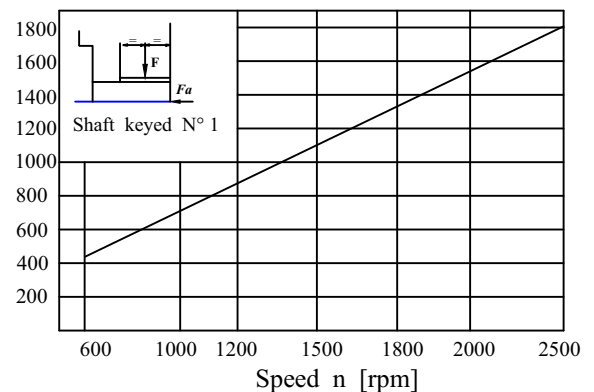

Maximum permissible axial load Fa = 1200 N

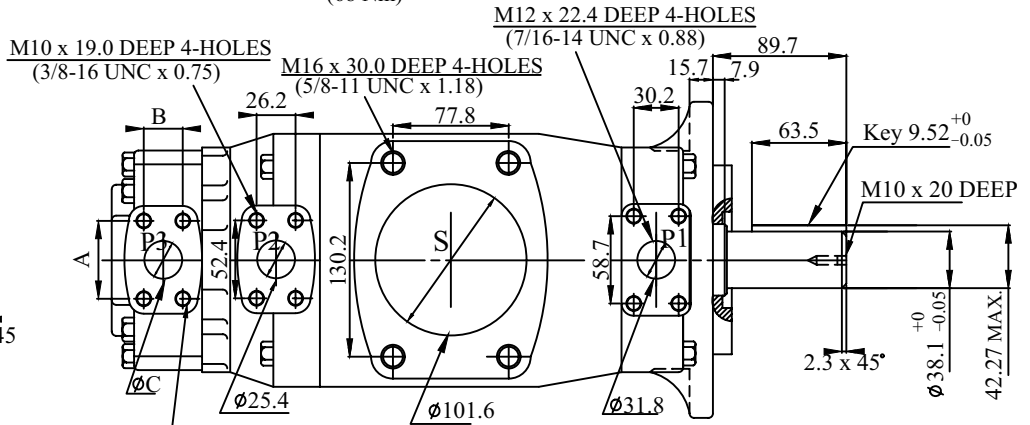
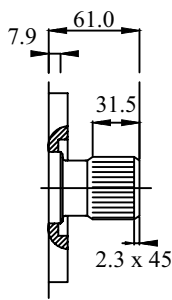
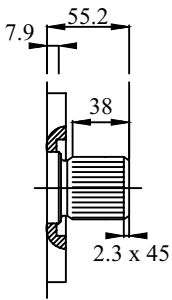
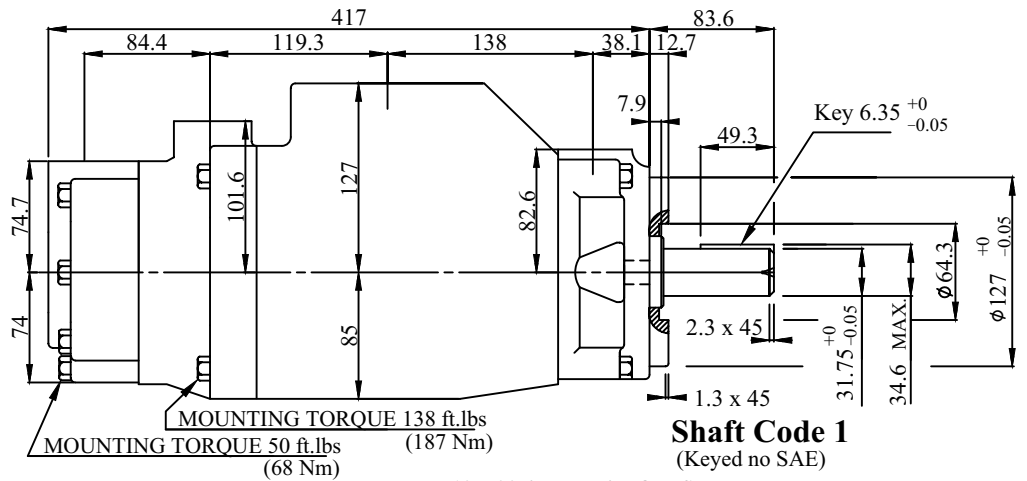
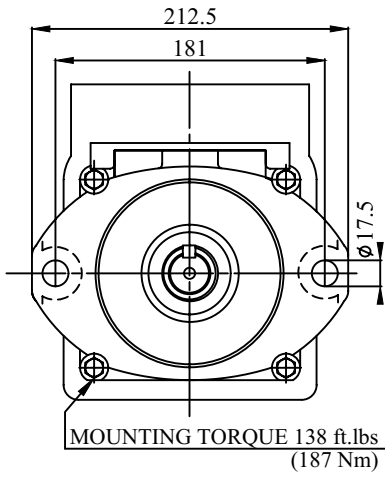

Shaft Code 3
SAE C splined shaft
Class 1-J498 b 12/24 dp.
-14 teeth 30°
pressure angle flat root
side fit

Shaft Code 4
SAE CC splined shaft
Class 1-J498 b 12/24 dp.
-17 teeth 30° pressure
angle flat root
side fit

M10 x 19.0 DEEP 4-HOLES (3/8-16 UNC x 0.75)

PORT	CODE	A	B	C
P3	00&M0	2.06(52.4)	1.03(26.2)	1.0(25.4)
	01&M1	1.874(47.6)	0.874(22.2)	0.75(19.05)

Shaft torque limits (mℓ/rev x bar)	
Shaft	Vp x p max.(P1+P2+P3)
1	43240
2	66500
3	61200
4	66500

OPERATING CHARACTERISTICS - TYPICAL (24 cST) (input power p (kw) for one cartridge only)

Pressure Port	Series	Volumetric Displacement Vp cm ³ /rev	Flow q & n =1500rpm (ℓ/min)			Input power p & n =1500rpm (KW)			P Max Kg/cm ²	Max r.p.m	
			P=0 bar	P=140 bar	P=240 bar	P=7 bar	P=140 bar	P=240 bar			
P1	014	47.6	71.4	62.1	55.9	2.3	18.5	30.6	240	2500	
	017	58.2	87.3	78.0	71.8	2.5	22.2	37.0			
	020	66.0	99.0	89.7	83.5	2.8	24.9	41.7			
	024	79.5	119.3	110.0	103.8	3.0	29.6	49.8			
	028	89.7	134.5	125.2	119.0	3.2	33.2	55.9			
	031	98.3	147.5	138.1	131.9	3.3	36.2	61.0			
	035	111.0	166.5	157.2	151.0	3.5	40.7	68.7			
	038	120.3	180.4	171.1	164.9	3.7	43.9	74.3			
	042 1)	136.0	204.0	194.7	188.5	4.0	49.4	83.7			
	045 1)	145.7	218.5	209.2	203.0	4.1	52.8	89.5			
050 1)	158.0	237.0	227.7	224.0 2)	4.4	57.0	85.0 2)	210	2200		
061 1)	190.5	285.7	278.0	—	4.6	60.6	—	120			
P2 - P3	003	10.8	16.2	11.2	7.7	1.3	5.3	8.4	275	2500	
	005	17.2	25.8	20.8	17.3	1.4	7.5	12.2			
	006	21.3	31.9	26.9	23.4	1.5	8.9	14.7			
	008	26.4	39.6	34.6	31.1	1.6	10.7	17.7			
	010	34.1	51.1	46.1	42.6	1.7	13.4	22.3			
	012	37.1	55.6	50.6	47.1	1.7	14.4	24.1			
	014	46.0	69.0	64.0	60.5	1.9	17.6	29.5			
	017	58.3	87.4	82.4	78.9	2.1	21.9	36.9			
	020	63.8	95.7	90.7	87.2	2.2	23.8	40.2			
	022	70.3	105.4	100.4	96.9	2.3	26.1	44.1			
	025	79.3	118.9	113.9	110.4	2.5	29.2	49.5			
	028	88.8	133.2	128.2	125.8 2)	2.8	32.7	48.5 2)			210
	031	100.0	150.0	145.0	142.6 2)	2.8	36.5	54.2 2)			

1) 042-045-050-061=2200rpm max.

2) 028-031-050=210 bar max. int.

3) 061=120 bar max. int.

061=80 bar cont. Min Speed : 600 rpm

KT6DDCS - 038 - 035 - 014 - 1 R 00 - B 1 - 00 *

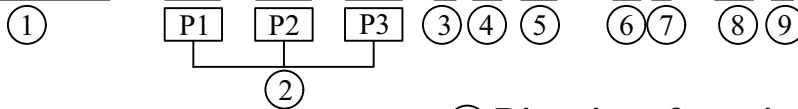

① Series

SAE C 6 bolts
Mounting flange J744 SAE C

② Cam ring for " P1 " & " P2 "

Volumetric displacement (cm³/rev)
014=47.6 035=111.0
017=58.2 038=120.3
020=66.0 042=136.0
024=79.5 045=145.7
028=89.7 050=158.0
031=98.3 061=190.5

Cam ring for " P3 "

003=10.8 017=58.3
005=17.2 020=63.8
006=21.3 022=70.3
008=26.4 025=79.3
010=34.1 028=88.8
012=37.1 031=100.0
014=46.0

③ Type of shaft

- 1 - Keyed (SAE C)
- 2 - Keyed (SAE CC)
- 3 - Splined (SAE C)
- 4 - Splined (SAE CC)
- 5 - Keyed (no SAE)

④ Direction of rotation(view on shaft end)

R=clockwise
L=counter-clockwise

⑤ Porting combination

00-standard

⑥ Design letter

⑦ Seal class

- 1-S1 (for mineral oil)
- 4-S4 (for fire resistant fluids)
- 5-S5 (for mineral oil and fire resistant fluids)

⑧ Port connection variables
SAE 4 bolt flange (J518c)

P1 & P2 = 1 1/4" S = 4"				
	Unc		Metric	
CODE	00	01	M0	M1
P3	1"	3/4"	1"	3/4"

⑨ Modifications

HYDROMECHANICAL POWER LOSS (TYPICAL)

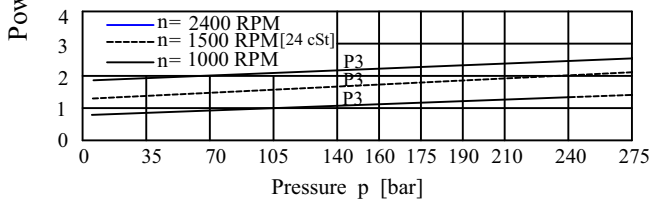
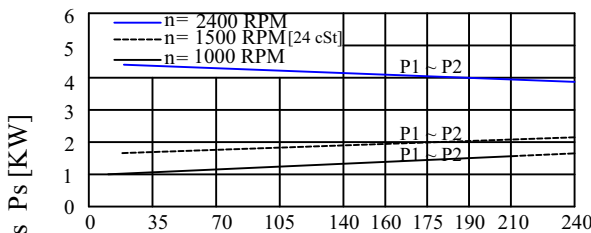

Total hydromechanical power loss is the sum of each section at its operating conditions.

INTERNAL LEAKAGE (TYPICAL)

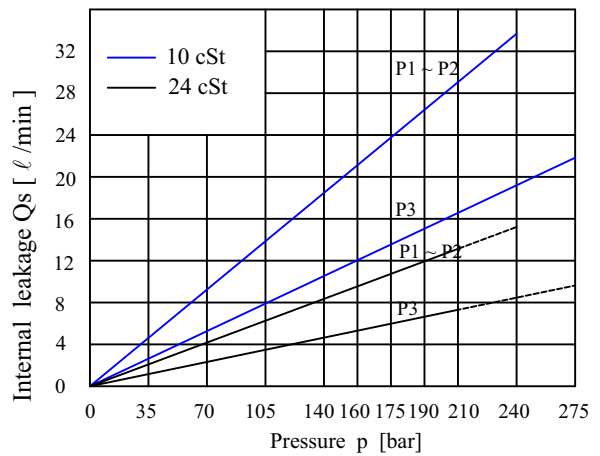

PERMISSIBLE RADIAL LOAD

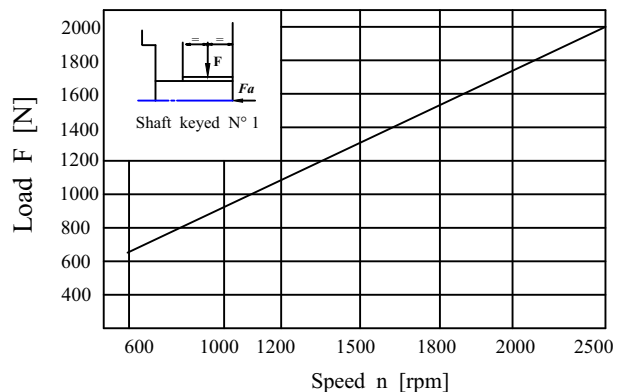

Maximum permissible axial load Fa = 1200 N

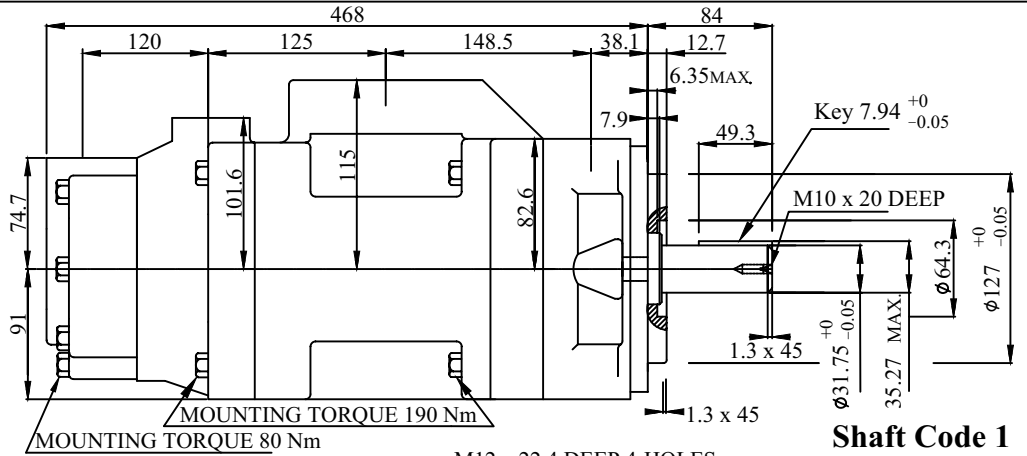
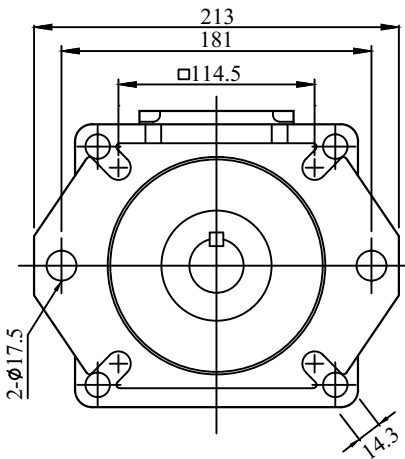

Shaft Code 1
(Keyed SAE C)

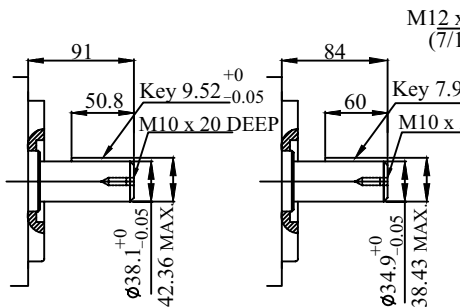

Shaft Code 2
(Keyed SAE CC)

Shaft Code 5
(Keyed no SAE)

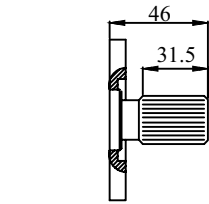

Shaft Code 4
SAE CC splined shaft
Class 1-J498 b 12/24d.p.
-17 teeth
30° pressure angle flat
root side fit

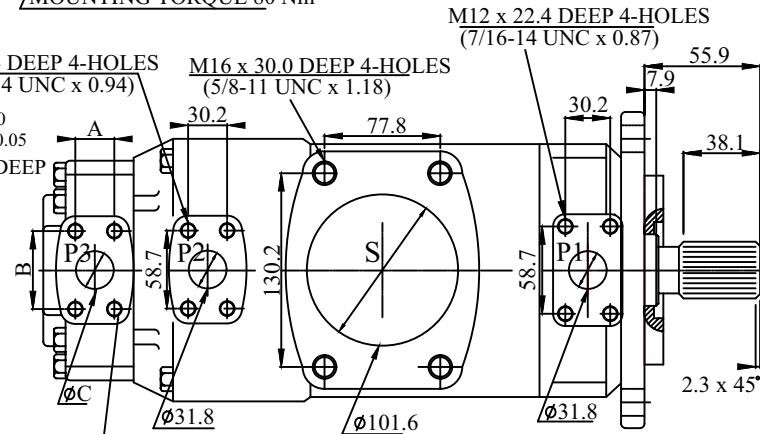

Shaft Code 3
SAE C splined shaft
Class 1-J498 b 12/24d.p.
-14 teeth
30° pressure angle flat
root side fit

M10 x 19.0 DEEP 4-HOLES
(3/8 -11 UNC x 0.75)

Alternate connect. variables		
	00 & M0	01 & M1
A	1.03 (26.2)	0.874 (22.2)
B	2.06 (52.4)	1.874 (47.6)
C	1.0 (25.4)	0.75 (19.05)

Shaft torque limits (mℓ/rev x bar)	
Shaft	Vp x p max. (P1+P2+P3)
1	43240
2	72306
3	61200
5	55600

OPERATING CHARACTERISTICS - TYPICAL (24 cST) (input power p (kw) for one cartridge only)

Pressure Port	Series	Volumetric Displacement Vp cm ³ /rev	Flow q & n =1500rpm (ℓ/min)			Input power p & n =1500rpm (KW)			P Max Kg/cm ²	Max r.p.m	
			P=0 bar	P=140 bar	P=240 bar	P=7 bar	P=140 bar	P=240 bar			
P1 ~ P2	014	47.6	71.4	62.1	55.9	2.3	18.5	30.6	240	2500	
	017	58.2	87.3	78.0	71.8	2.5	22.2	37.0			
	020	66.0	99.0	89.7	83.5	2.8	24.9	41.7			
	024	79.5	119.3	110.0	103.8	3.0	29.6	49.8			
	028	89.7	134.5	125.2	119.0	3.2	33.2	55.9			
	031	98.3	147.5	138.1	131.9	3.3	36.2	61.0			
	035	111.0	166.5	157.2	151.0	3.5	40.7	68.7			
	038	120.3	180.4	171.1	164.9	3.7	43.9	74.3			
	042 1)	136.0	204.0	194.7	188.5	4.0	49.4	83.7			
	045 1)	145.7	218.5	209.2	203.0	4.1	52.8	89.5			
050 1)	158.0	237.0	227.7	224.0 2)	4.4	57.0	85.0 2)	210	2200		
061 1)	190.5	285.7	278.0 3)	—	4.6	60.6 3)	—	120			
P3	003	10.8	16.2	11.2	7.7	1.3	5.3	8.4	275	2500	
	005	17.2	25.8	20.8	17.3	1.4	7.5	12.2			
	006	21.3	31.9	26.9	23.4	1.5	8.9	14.7			
	008	26.4	39.6	34.6	31.1	1.6	10.7	17.7			
	010	34.1	51.1	46.1	42.6	1.7	13.4	22.3			
	012	37.1	55.6	50.6	47.1	1.7	14.4	24.1			
	014	46.0	69.0	64.0	60.5	1.9	17.6	29.5			
	017	58.3	87.4	82.4	78.9	2.1	21.9	36.9			
	020	63.8	95.7	90.7	87.2	2.2	23.8	40.2			
	022	70.3	105.4	100.4	96.9	2.3	26.1	44.1			
	025	79.3	118.9	113.9	110.4	2.5	29.2	49.5			
	028	88.8	133.2	128.2	125.8 2)	2.8	32.7	48.5 2)			210
	031	100.0	150.0	145.0	142.6 2)	2.8	36.5	54.2 2)			

1) 042-045-050-061=2200RPM max.

2) 028-031-050=210 bar max.

3) 061=120 bar max. int.
061=80 bar cont.

Min Speed : 600 rpm

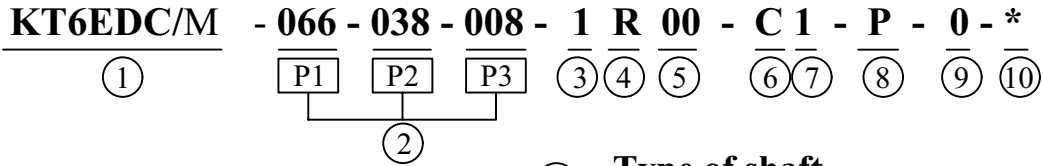

① **Series**

② **Cam ring for " P1 "**

Volumetric displacement (cm³/rev)

042=132.3	062=196.7
045=142.4	066=213.3
050=158.5	072=227.1
052=164.8	085=269.8
057=180.7	

Cam ring for " P2 "

014=47.6	035=111.0
017=58.2	038=120.3
020=66.0	042=136.0
024=79.5	045=145.7
028=89.7	050=158.0
031=98.3	061=190.5

Cam ring for " P3 "

003=10.8	017=58.3
005=17.2	020=63.8
006=21.3	022=70.3
008=26.4	025=79.3
010=34.1	028=88.8
012=37.1	031=100.0
014=46.0	

③ **Type of shaft**

- 1 - Keyed (G45N-ISO 3019-2)
- 2 - Keyed (SAE D & E)
- 3 - Splined

④ **Direction of rotation(view on shaft end)**

- R=clockwise
- L=counter-clockwise

⑤ **Porting combination**

- 00-standard

⑥ **Design letter**

⑦ **Seal class**

- 1-S1 (for mineral oil)
- 4-S4 (for fire resistant fluids)
- 5-S5 (for mineral oil and fire resistant fluids)

⑧ **Mounting (pump)**

- P=Pedestal mounting
- F=Face mounting

⑨ **Mounting W/connection variables**

- 0=P3=1" SAE
- 1=P3=3/4" SAE

⑩ **Modifications**

HYDROMECHANICAL POWER LOSS (TYPICAL)

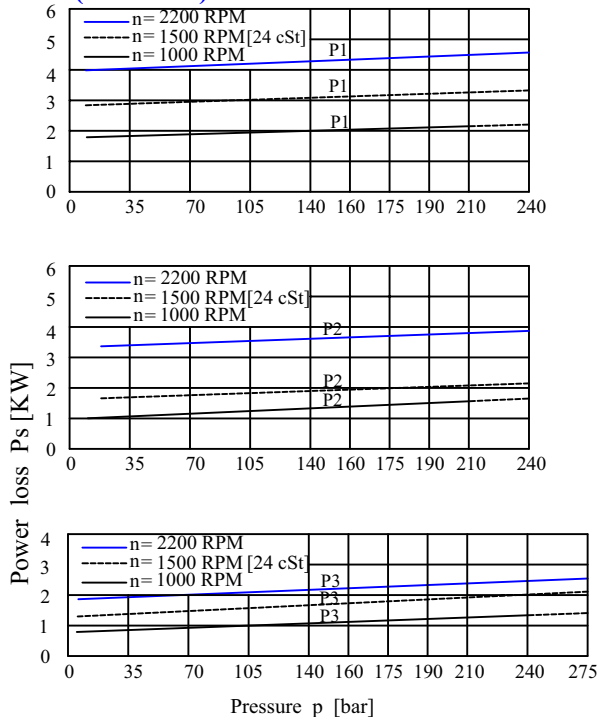

Total hydromechanical power loss is the sum of each section at its operating conditions.

INTERNAL LEAKAGE (TYPICAL)

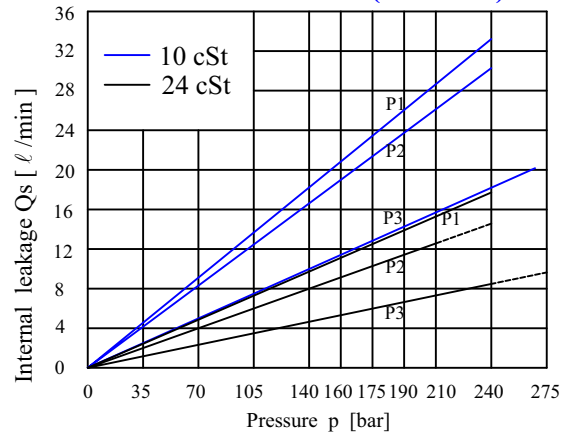

PERMISSIBLE RADIAL LOAD

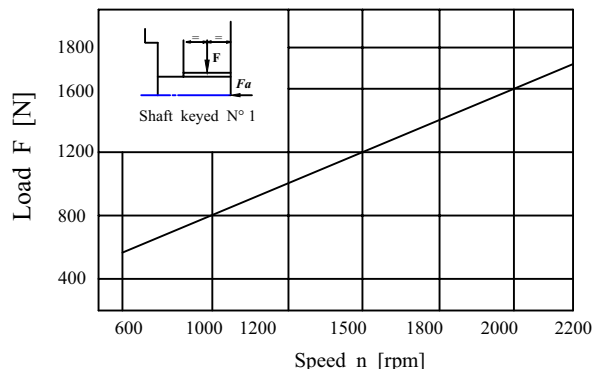

Maximum permissible axial load Fa = 2000 N

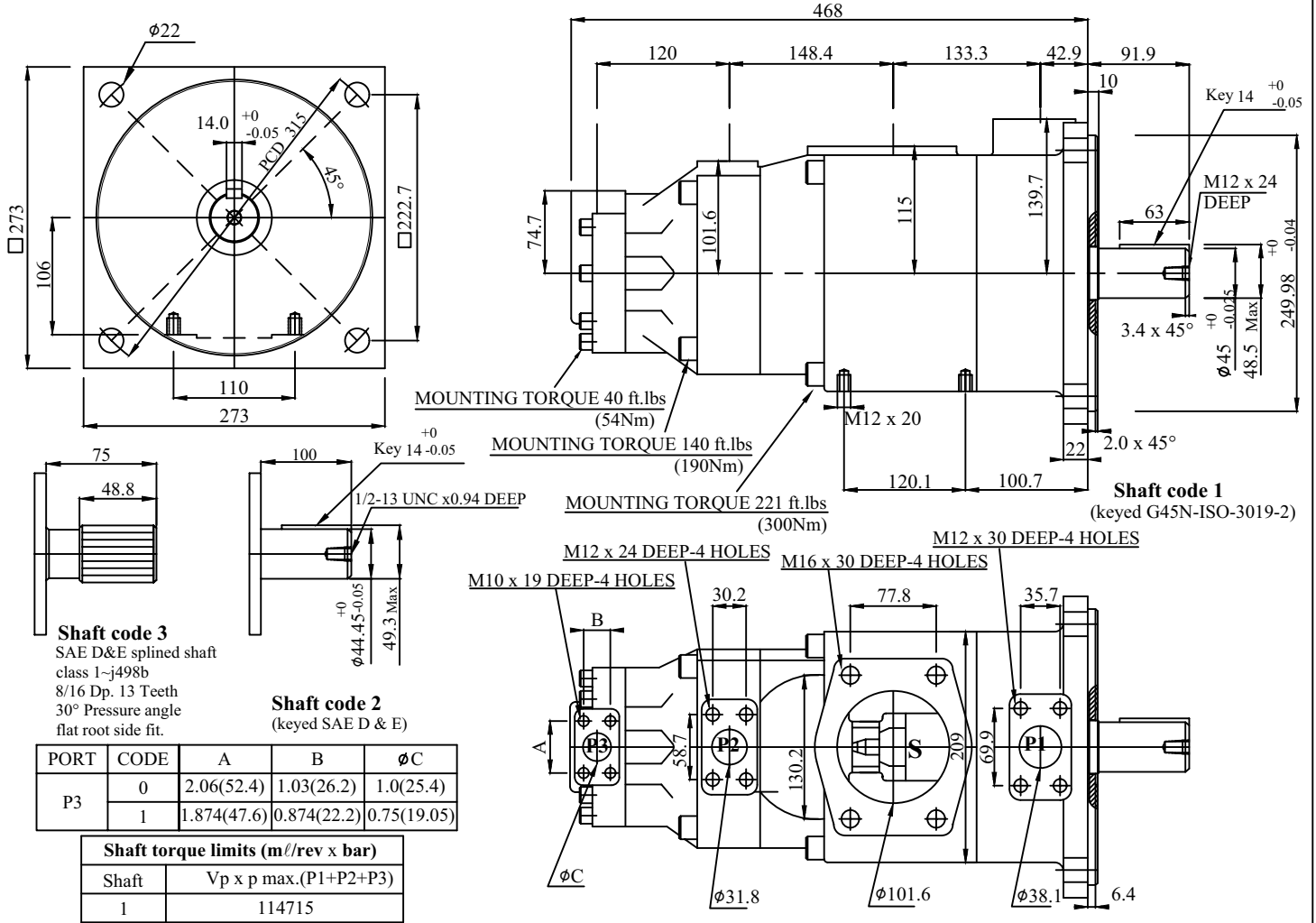

OPERATING CHARACTERISTICS - TYPICAL (24 cST) (input power p (kw) for one cartridge only)

Pressure Port	Series	Volumetric Displacement Vp cm ³ /rev	Flow q & n=1500rpm (ℓ/min)			Input power p & n =1500rpm (KW)			P Max Kg/cm ²	Max r.p.m
			P=0 bar	P=140 bar	P=240 bar	P=7 bar	P=140 bar	P=240 bar		
P1	042	132.3	198.5	188.5	181.3	5.2	49.4	82.6	240	2200
	045	142.4	213.6	203.6	196.5	5.4	52.9	88.7		
	050	158.5	237.7	227.7	220.6	5.7	58.5	98.3		
	052	164.8	247.2	237.2	230.1	5.8	60.8	102.1		
	057	180.7	271.1	261.1	254.0	6.1	66.4	106.9		
	062	196.7	295.0	285.0	277.9	6.4	71.9	121.3		
	066	213.3	319.9	309.9	302.8	6.7	77.7	131.2		
	072	227.1	340.6	330.6	323.5	6.9	82.6	139.5		
P2	085 1)	269.8	404.7	397.7 2)	—	7.3	65.3 2)	—	240	2200
	014	47.6	71.4	62.1	55.9	2.3	18.5	30.6		
	017	58.2	87.3	78.0	71.8	2.5	22.2	37.0		
	020	66.0	99.0	89.7	83.5	2.8	24.9	41.7		
	024	79.5	119.3	110.0	103.8	3.0	29.6	49.8		
	028	89.7	134.5	125.2	119.0	3.2	33.2	55.9		
	031	98.3	147.5	138.1	131.9	3.3	36.2	61.0		
	035	111.0	166.5	157.2	151.0	3.5	40.7	68.7		
	038	120.3	180.4	171.1	164.9	3.7	43.9	74.3		
	042	136.0	204.0	194.7	188.5	4.0	49.4	83.7		
	045	145.7	218.5	209.2	203.0	4.1	52.8	89.5		
	050	158.0	237.0	227.7	224.0 3)	4.4	57.0	85.0 3)		
	061	190.5	285.7	278.0 4)	—	4.6	60.6 4)	—		
	P3	003	10.8	16.2	11.2	7.7	1.3	5.3		
005		17.2	25.8	20.8	17.3	1.4	7.5	12.2		
006		21.3	31.9	26.9	23.4	1.5	8.9	14.7		
008		26.4	39.6	34.6	31.1	1.6	10.7	17.7		
010		34.1	51.1	46.1	42.6	1.7	13.4	22.3		
012		37.1	55.6	50.6	47.1	1.7	14.4	24.1		
014		46.0	69.0	64.0	60.5	1.9	17.6	29.5		
017		58.3	87.4	82.4	78.9	2.1	21.9	36.9		
020		63.8	95.7	90.7	87.2	2.2	23.8	40.2		
022		70.3	105.4	100.4	96.9	2.3	26.1	44.1		
025		79.3	118.9	113.9	110.4	2.5	29.2	49.5		
028		88.8	133.2	128.2	125.8 3)	2.8	32.7	48.5 3)		
031		100.0	150.0	145.0	142.6 3)	2.8	36.5	54.2 3)		

1) 085=2000RPM max. 2) 085=75 bar cont. 085=90 bar max. int. 3) 028-031-050=210 bar max.
 4) 061=120 bar max. int. 061=80 bar cont.

Min Speed : 600 rpm

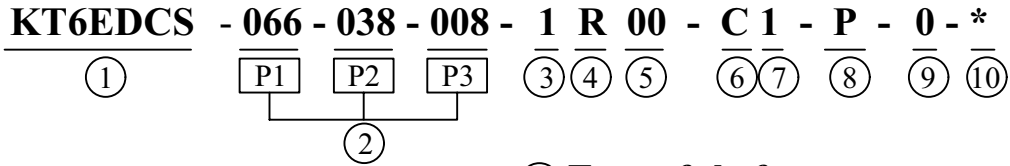

① **Series**

② **Cam ring for " P1 "**

Volumetric displacement (cm³/rev)

042=132.3	062=196.7
045=142.4	066=213.3
050=158.5	072=227.1
052=164.8	085=269.8
057=180.7	

Cam ring for " P2 "

014=47.6	035=111.0
017=58.2	038=120.3
020=66.0	042=136.0
024=79.5	045=145.7
028=89.7	050=158.0
031=98.3	061=190.5

Cam ring for " P3 "

003=10.8	017=58.3
005=17.2	020=63.8
006=21.3	022=70.3
008=26.4	025=79.3
010=34.1	028=88.8
012=37.1	031=100.0
014=46.0	

③ **Type of shaft**

- 1 - Keyed (G45N-ISO 3019-2)
- 2 - Keyed (SAE D & E)
- 3 - Splined

④ **Direction of rotation(view on shaft end)**

- R=clockwise
- L=counter-clockwise

⑤ **Porting combination**

- 00-standard

⑥ **Design letter**

⑦ **Seal class**

- 1-S1 (for mineral oil)
- 4-S4 (for fire resistant fluids)
- 5-S5 (for mineral oil and fire resistant fluids)

⑧ **Mounting (pump)**

- P=Pedestal mounting
- F=Face mounting

⑨ **Mounting W/connection variables**

- 0=P3=1" SAE
- 1=P3=3/4" SAE

⑩ **Modifications**

HYDROMECHANICAL POWER LOSS (TYPICAL)

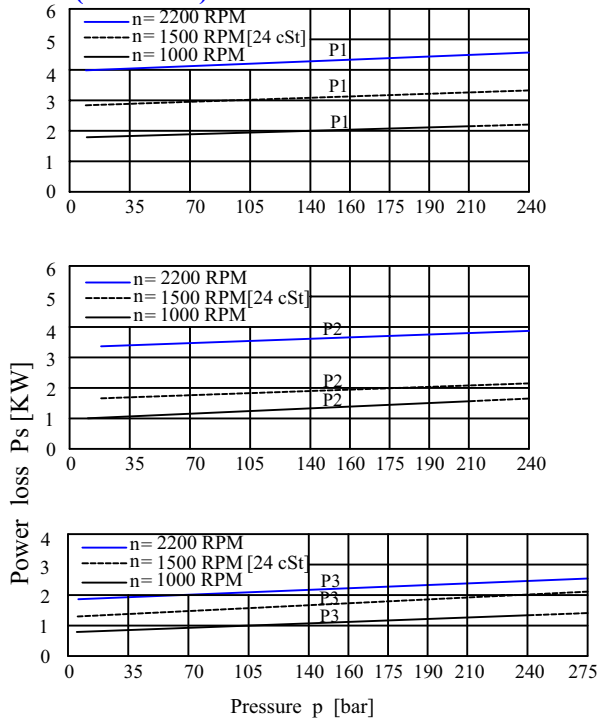

Total hydromechanical power loss is the sum of each section at its operating conditions.

INTERNAL LEAKAGE (TYPICAL)

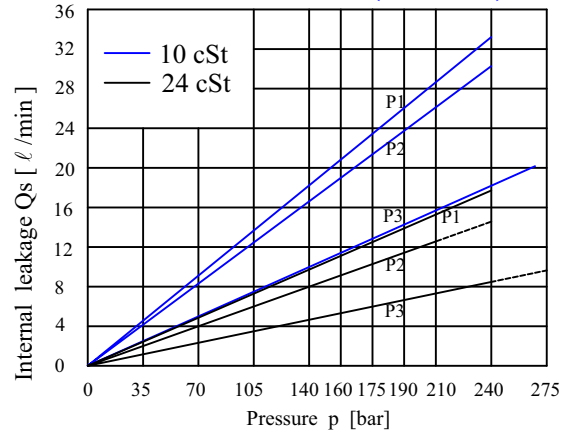

PERMISSIBLE RADIAL LOAD

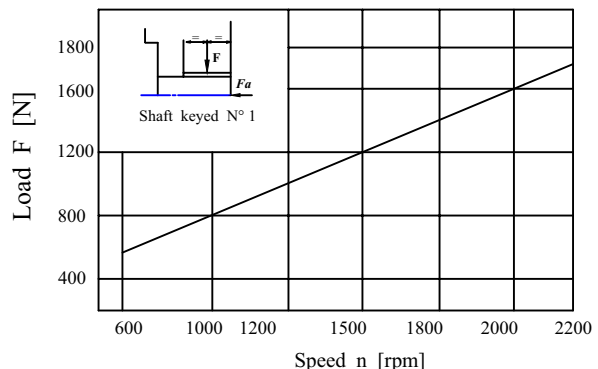

Maximum permissible axial load Fa = 2000 N

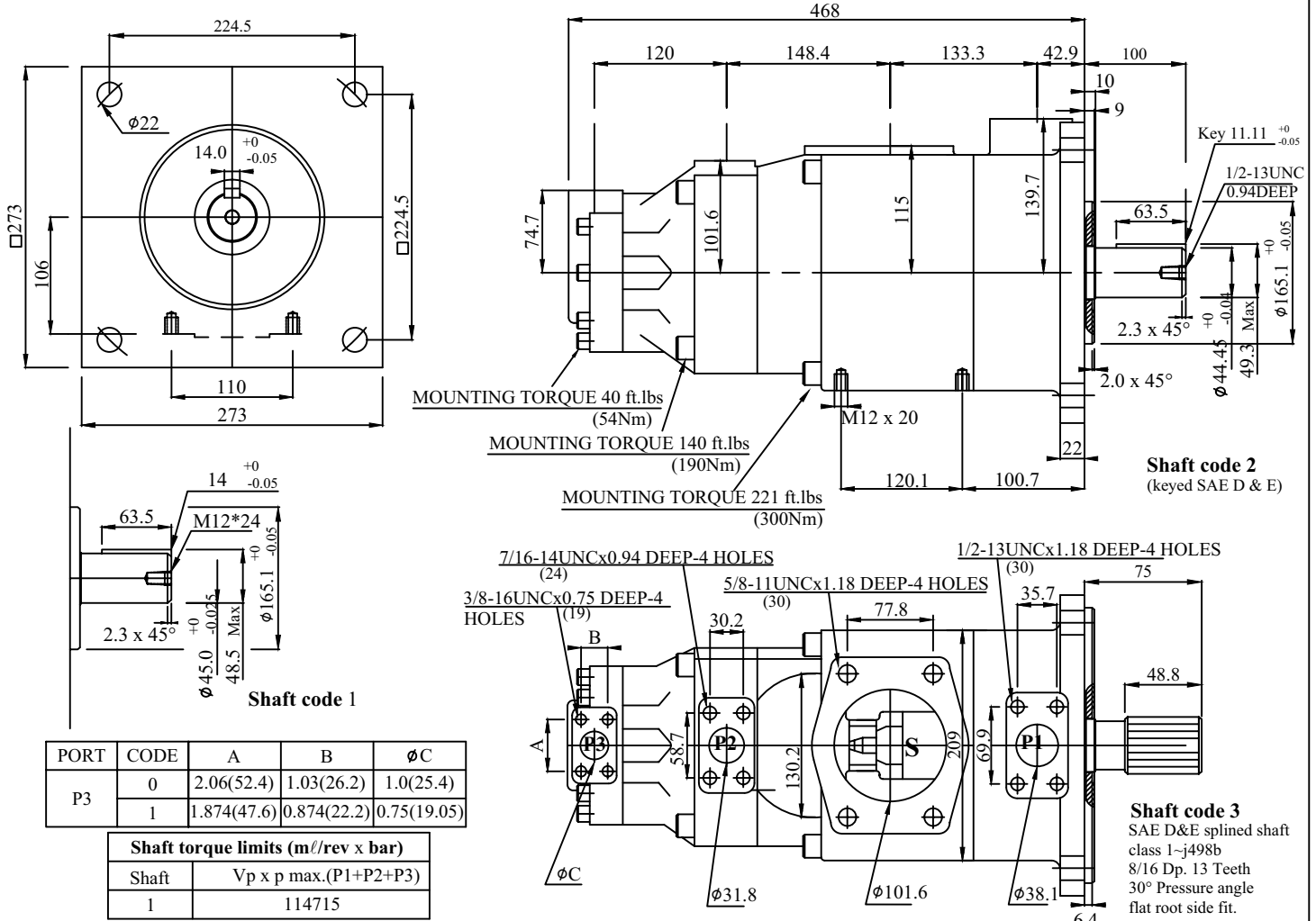

PORT	CODE	A	B	φC
P3	0	2.06(52.4)	1.03(26.2)	1.0(25.4)
	1	1.874(47.6)	0.874(22.2)	0.75(19.05)

Shaft torque limits (mℓ/rev x bar)	
Shaft	Vp x p max.(P1+P2+P3)
1	114715

OPERATING CHARACTERISTICS - TYPICAL (24 cST) (input power p (kw) for one cartridge only)

Pressure Port	Series	Volumetric Displacement Vp cm ³ /rev	Flow q & n=1500rpm (ℓ/min)			Input power p & n =1500rpm (KW)			P Max Kg/cm ²	Max r.p.m
			P=0 bar	P=140 bar	P=240 bar	P=7 bar	P=140 bar	P=240 bar		
P1	042	132.3	198.5	188.5	181.3	5.2	49.4	82.6	240	2200
	045	142.4	213.6	203.6	196.5	5.4	52.9	88.7		
	050	158.5	237.7	227.7	220.6	5.7	58.5	98.3		
	052	164.8	247.2	237.2	230.1	5.8	60.8	102.1		
	057	180.7	271.1	261.1	254.0	6.1	66.4	106.9		
	062	196.7	295.0	285.0	277.9	6.4	71.9	121.3		
	066	213.3	319.9	309.9	302.8	6.7	77.7	131.2		
	072	227.1	340.6	330.6	323.5	6.9	82.6	139.5		
P2	085 1)	269.8	404.7	397.7 2)	—	7.3	65.3 2)	—	240	2200
	014	47.6	71.4	62.1	55.9	2.3	18.5	30.6		
	017	58.2	87.3	78.0	71.8	2.5	22.2	37.0		
	020	66.0	99.0	89.7	83.5	2.8	24.9	41.7		
	024	79.5	119.3	110.0	103.8	3.0	29.6	49.8		
	028	89.7	134.5	125.2	119.0	3.2	33.2	55.9		
	031	98.3	147.5	138.1	131.9	3.3	36.2	61.0		
	035	111.0	166.5	157.2	151.0	3.5	40.7	68.7		
	038	120.3	180.4	171.1	164.9	3.7	43.9	74.3		
	042	136.0	204.0	194.7	188.5	4.0	49.4	83.7		
	045	145.7	218.5	209.2	203.0	4.1	52.8	89.5		
	050	158.0	237.0	227.7	224.0 3)	4.4	57.0	85.0 3)		
P3	061	190.5	285.7	278.0 4)	—	4.6	60.6 4)	—	210	2200
	061	190.5	285.7	278.0 4)	—	4.6	60.6 4)	—	120	
P3	003	10.8	16.2	11.2	7.7	1.3	5.3	8.4	275	2200
	005	17.2	25.8	20.8	17.3	1.4	7.5	12.2		
	006	21.3	31.9	26.9	23.4	1.5	8.9	14.7		
	008	26.4	39.6	34.6	31.1	1.6	10.7	17.7		
	010	34.1	51.1	46.1	42.6	1.7	13.4	22.3		
	012	37.1	55.6	50.6	47.1	1.7	14.4	24.1		
	014	46.0	69.0	64.0	60.5	1.9	17.6	29.5		
	017	58.3	87.4	82.4	78.9	2.1	21.9	36.9		
	020	63.8	95.7	90.7	87.2	2.2	23.8	40.2		
	022	70.3	105.4	100.4	96.9	2.3	26.1	44.1		
	025	79.3	118.9	113.9	110.4	2.5	29.2	49.5		
	028	88.8	133.2	128.2	125.8 3)	2.8	32.7	48.5 3)		
	031	100.0	150.0	145.0	142.6 3)	2.8	36.5	54.2 3)		

1) 085=2000RPM max. 2) 085=75 bar cont. 085=90 bar max. int. 3) 028-031-050=210 bar max. Min Speed : 600 rpm
 4) 061=120 bar max. int. 061=80 bar cont.