

VQ215 SVQ215
VQ225 SVQ315
VQ325 DVQ425
VQ425 SVQ425
VQ435 SVQ435
DVQ435

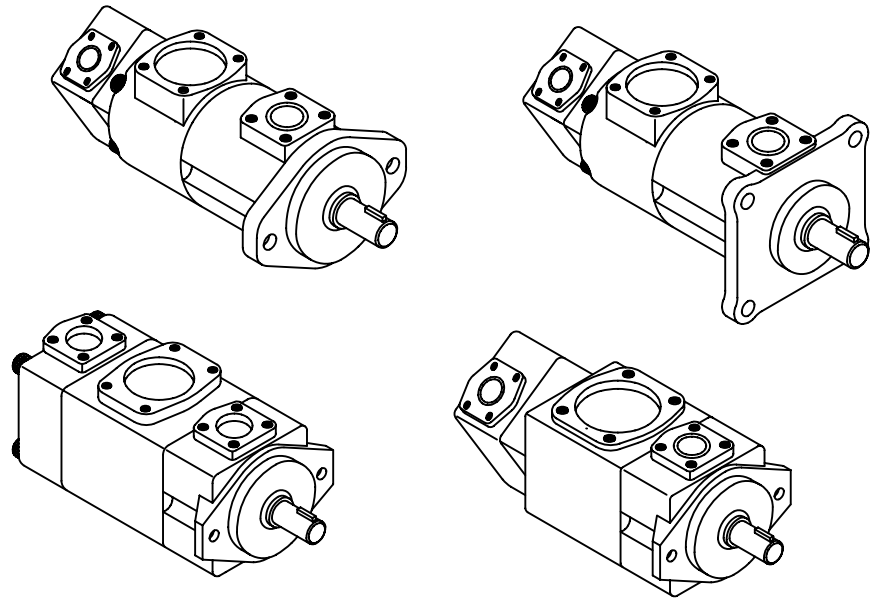

ORDERING CODE

雙泵訂購指引

EX : (VQ215-26-17-F-RALD-02)

EX : (SVQ315-94-17-F-RAAA-02)

Series Number 型式	P1:Discharge Port c.c/rev Shaft End P1-出油口 (近心軸端)	P2:Discharge Port c.c/rev Cover End P2-出油口 (近上蓋端)	Mounting Type 安裝方式	Shaft Rotation (view from Shaft End) 心軸轉向 (由心軸方向看)	Discharge Port Position (P1) Shaft End Pump (view from Shaft End) P1 出口位置方向 (由心軸方向看)	Suction Port Position (view from Shaft End) S進口位置方向 (由心軸方向看)	Discharge Port Position (P2) Cover End Pump (view from Shaft End) P2 出口位置方向 (由心軸方向看)	Shaft Type 心軸種類
VQ225	18,22,26,32 38,43,47,52 60,65,75	18,22,26,32 38,43,47,52 60,65,75	F: Flange Type 法蘭型	R: Clockwise 順時針	A:Upward (normal) 向上	A:Upward (normal) 向上	A:Upward 向上 (normal) B:Downward 向下 R:Right Hand 右向 L:Left Hand 左向	-01 -02 -03
SVQ315	60,66,76 82,88,94 108,116,125	6,8,11,14 17,19,23 26,31,38						
VQ215 SVQ215	18,22,26,32 38,43,47,52 60,65,75	6,8,11,14 17,19,23 26,31,38	L: Foot Type 腳座型	L: Anti-Clockwise 反時針	B:Downward 向下 R:Right Hand 右向 L:Left Hand 左向	B:Downward 向下 R:Right Hand 右向 L:Left Hand 左向	A:On Right Hand Upward 45° (normal) 右上45° B:On Right Hand Downward 45° 右下45° C:On Left Hand Downward 45° 左下45° D:On Left Hand Upward 45° 左上45°	
VQ325	60,66,76 82,88,94 108,116,125	18,22,26,32 38,43,47,52 60,65,75						
VQ425 SVQ425 DVQ425	136,156 189,200 216,237	18,22,26,32 38,43,47,52 60,65,75						
VQ435 SVQ435 DVQ435	136,156 189,200 216,237	60,66,76,82 88,94,108 116,125						

DOUBLE PUMP WEIGHT LIST(Kg)

雙泵重量表 (Kg)

	VQ215	VQ225	SVQ215	SVQ315	VQ325	VQ425	DVQ425	SVQ425	VQ435	DVQ435	SVQ435
Flange Type	24	30.6	32	44.4	50	63	73	80	76	84	91
Foot Type	29	35.5	40	52	58	71	104	111	93	115	122
Outlet & Inlet Flange	2.5	3.2	3.2	3.5	3.5	4.8	4.8	4.8	5.2	5.2	5.2

VQ215

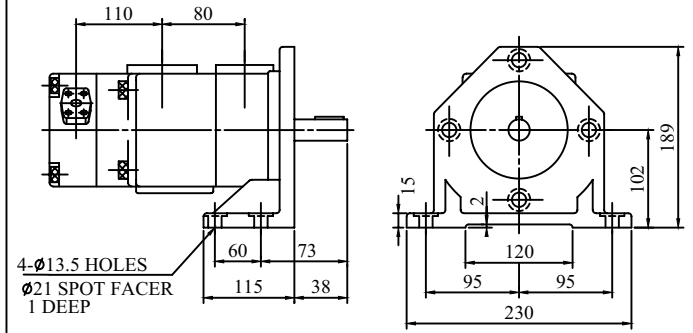
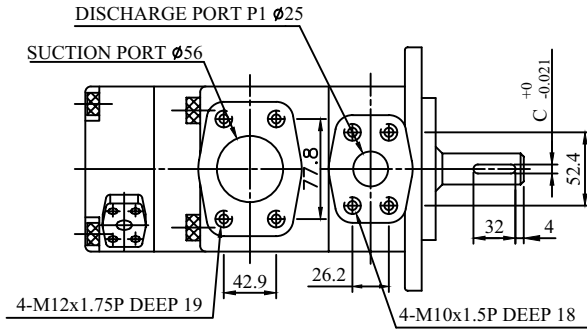

Foot Type (腳座型)

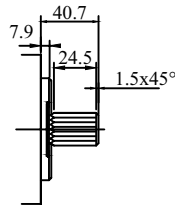
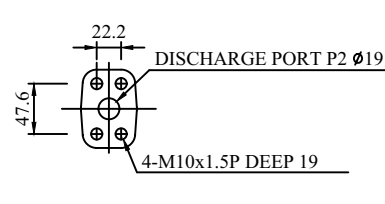

NO.04-Shaft
16/32 d.p. -13 teeth
30° pressure angle
Flat root side fit.

	A	B	C	L
NO.01-Shaft	$\phi 22.23$	24.5	6.35	61
NO.02-Shaft	$\phi 25.4$	28.18	6.35	61
NO.03-Shaft	$\phi 30$	33	7	68
NO.04-Shaft	Spline shaft 7/8" -13T			

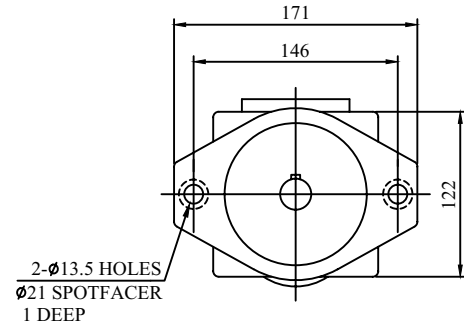
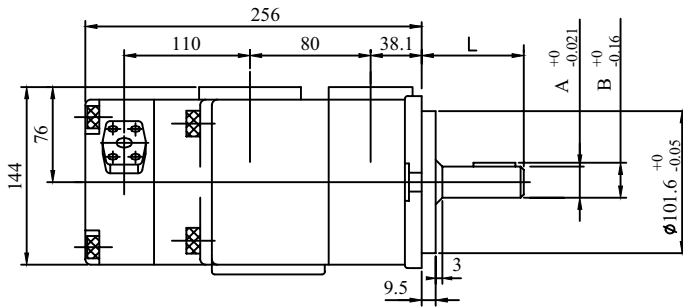

SVQ215

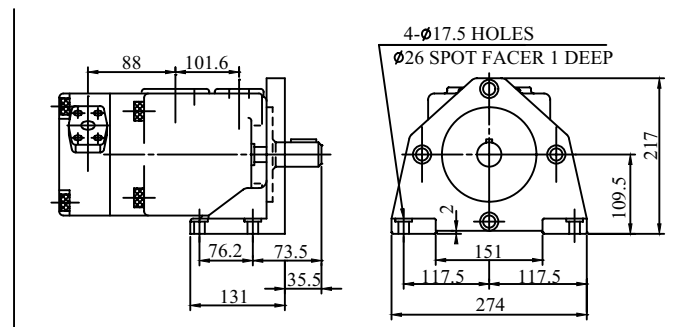
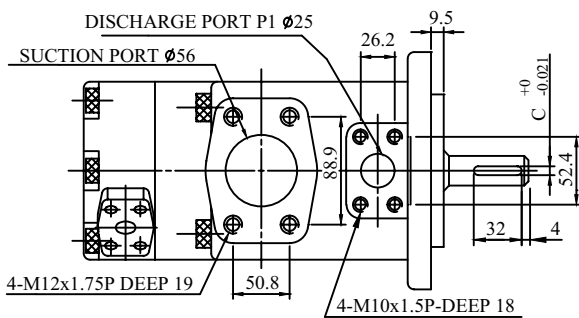

Foot Type (腳座型)

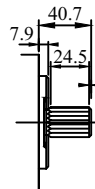
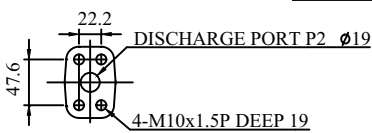

NO.04-Shaft
16/32 d.p. 13teeth
30° pressure angle
Flat root side fit.

	A	B	C	L
NO.01-Shaft	$\phi 22.23$	24.5	6.35	61
NO.02-Shaft	$\phi 25.4$	28.18	6.35	61
NO.03-Shaft	$\phi 30$	33	7	68
NO.04-Shaft	Spline shaft 7/8" -13T			

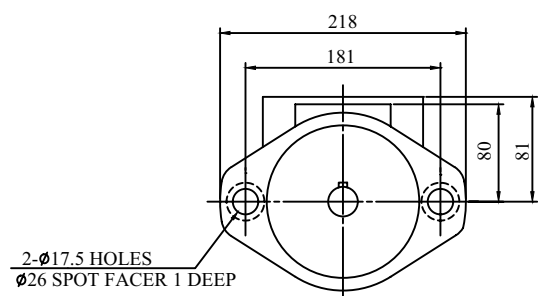
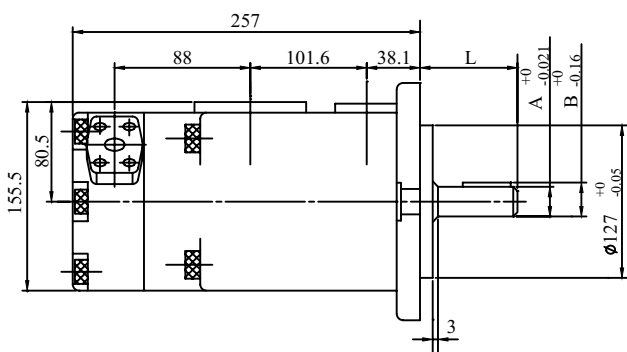

VQ225

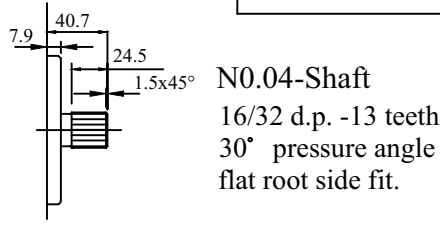
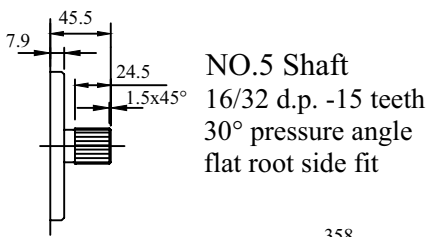
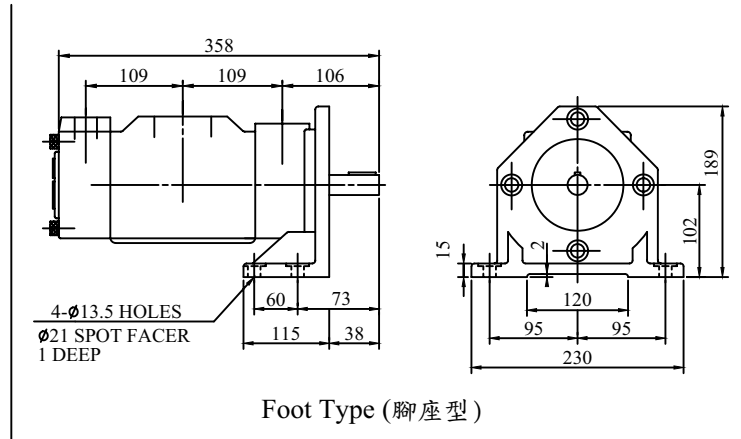
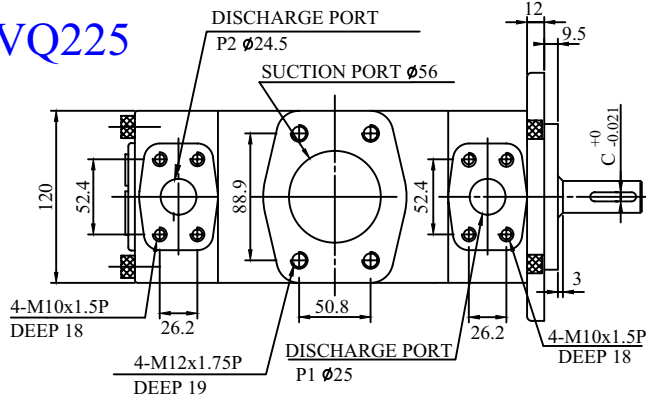

	A	B	C
NO.01-Shaft	$\phi 22.23$	24.5	6.35
NO.02-Shaft	$\phi 25.4$	28.18	6.35
NO.03-Shaft	$\phi 30$	33	7
NO.04-Shaft	Spline shaft 7/8" -13T		
NO.05-Shaft	Spline shaft 1" -15T		

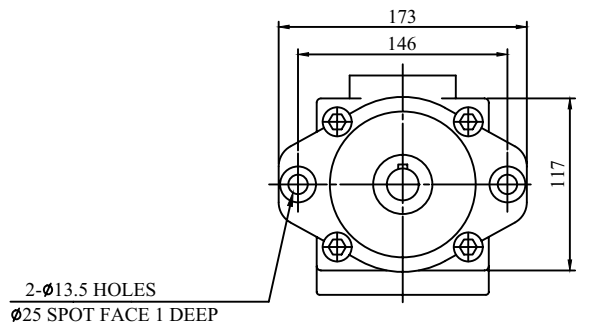
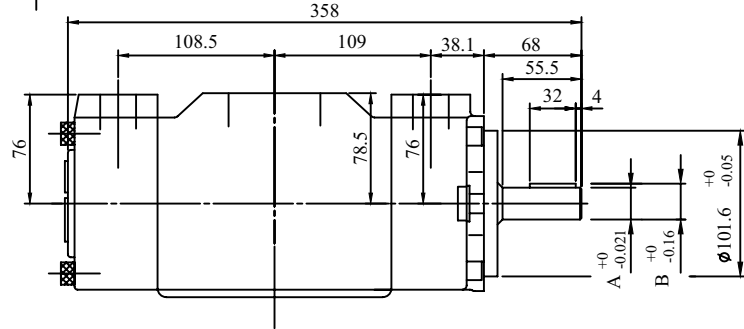

SVQ315

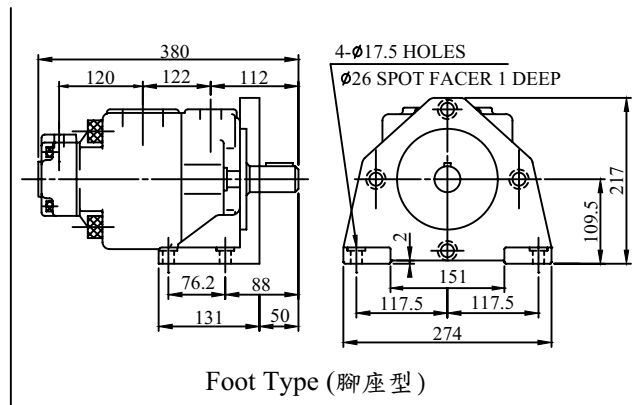
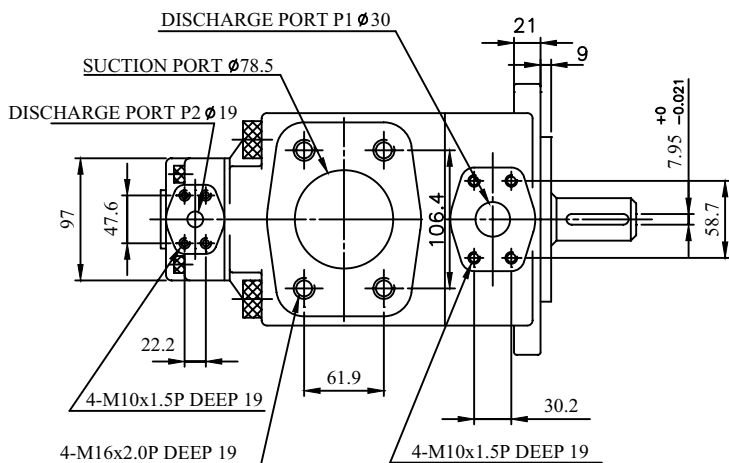

	A	B
NO.01-Shaft	$\phi 31.75$	35.32
NO.02-Shaft	$\phi 34.9$	38.56

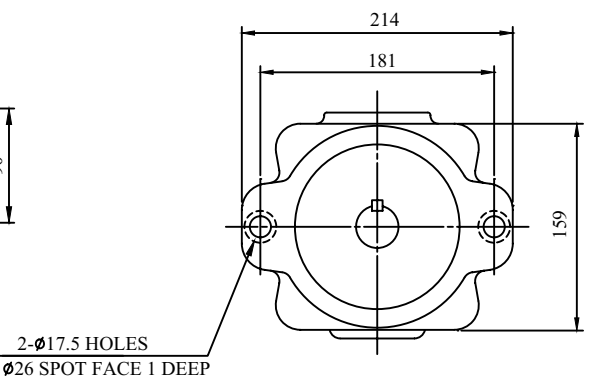
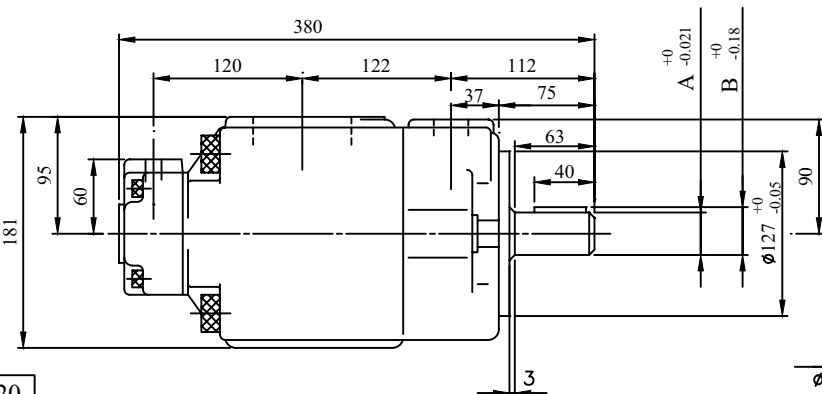

VQ325

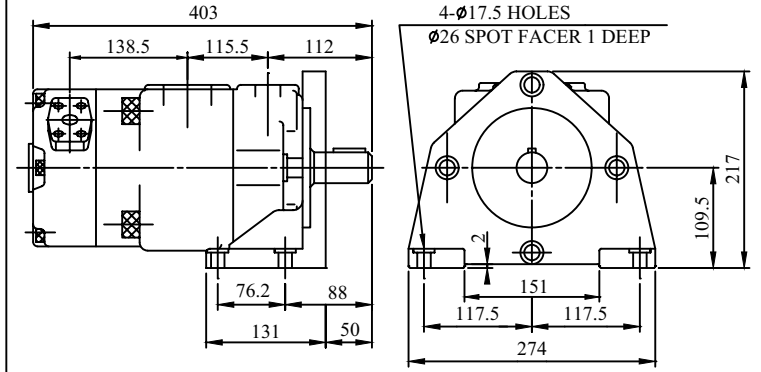
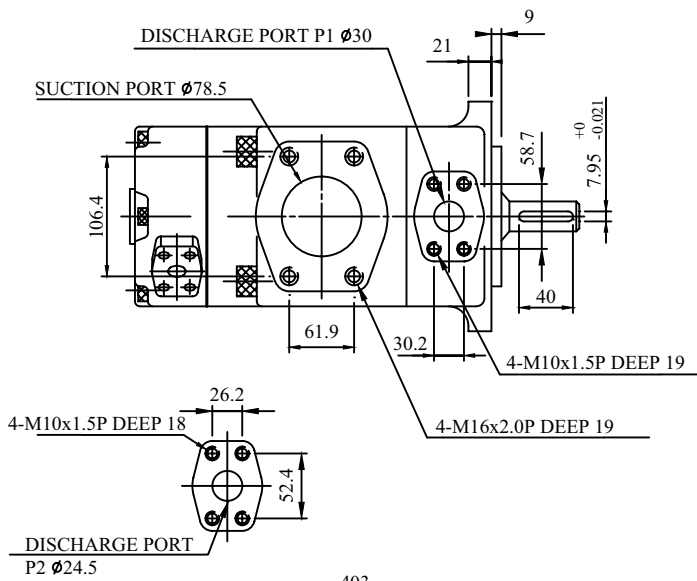

Foot Type (腳座型)

	A	B
NO.01-Shaft	$\phi 31.75$	35.32
NO.02-Shaft	$\phi 34.9$	38.56

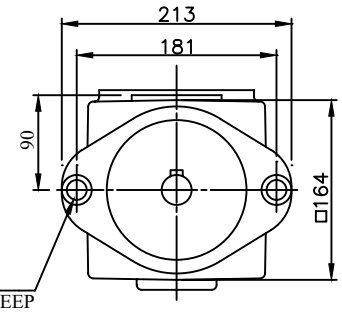
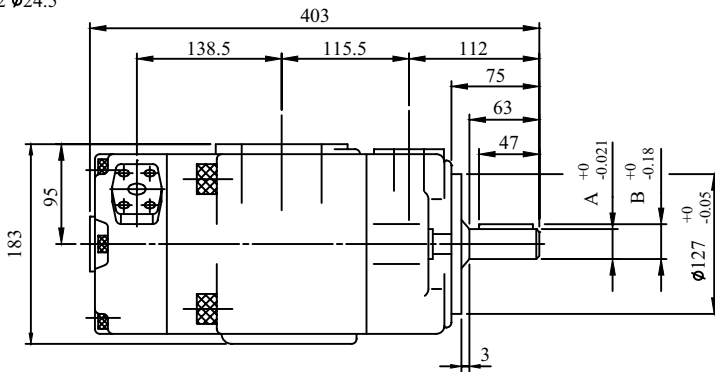

VQ425

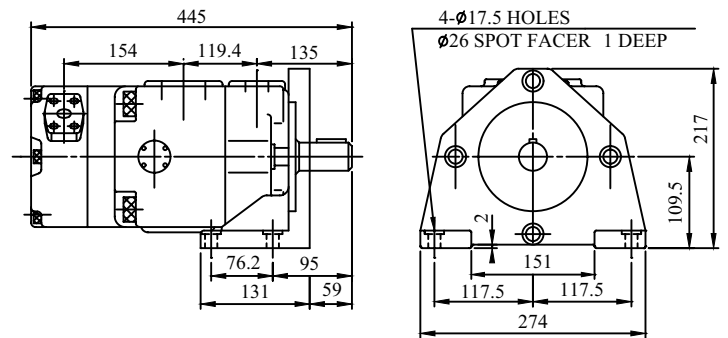
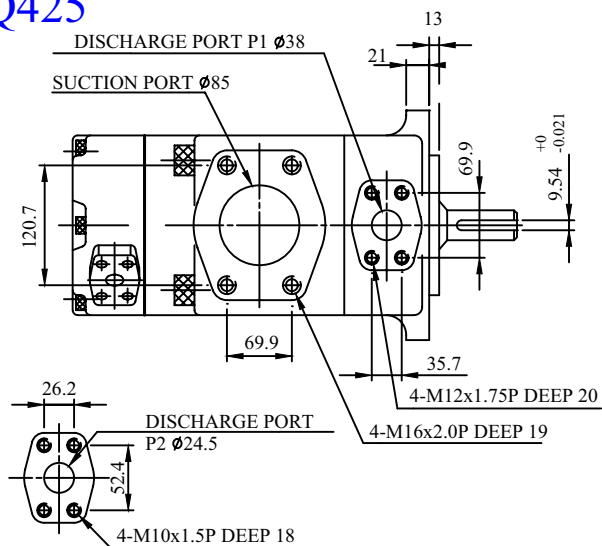

Foot Type (腳座型)

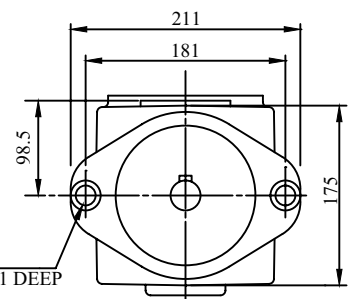
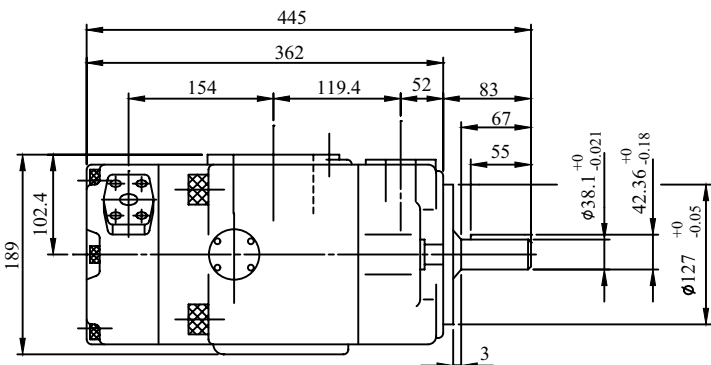

DVQ425

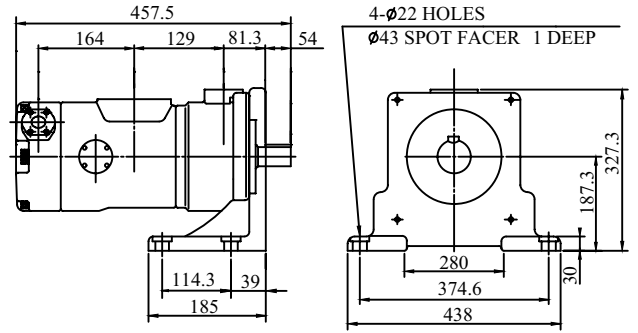
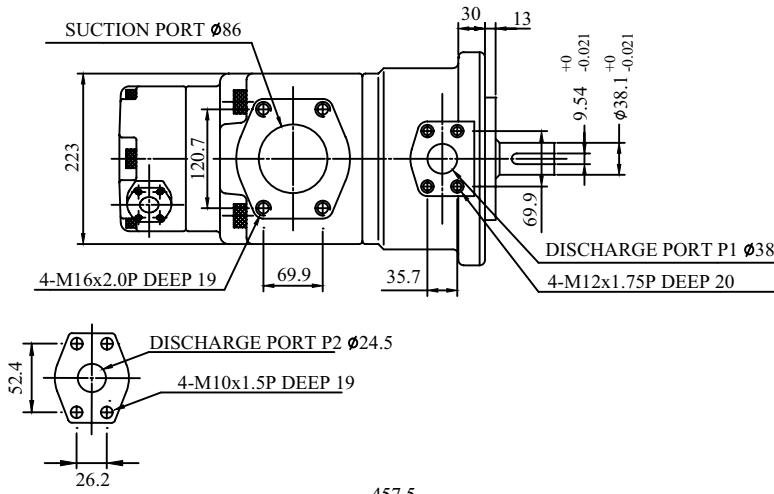

Foot Type (腳座型)

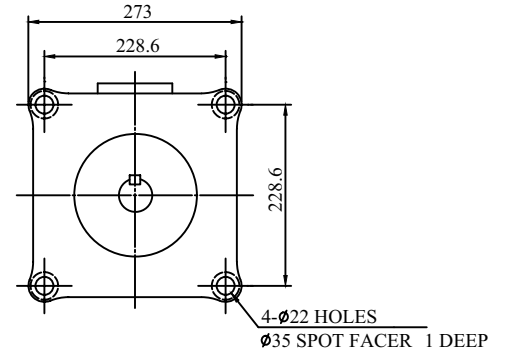
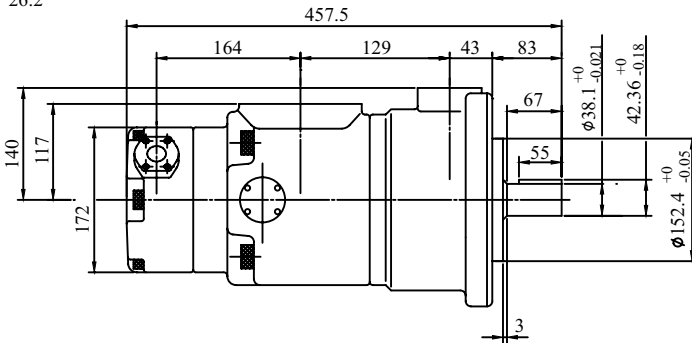

SVQ425

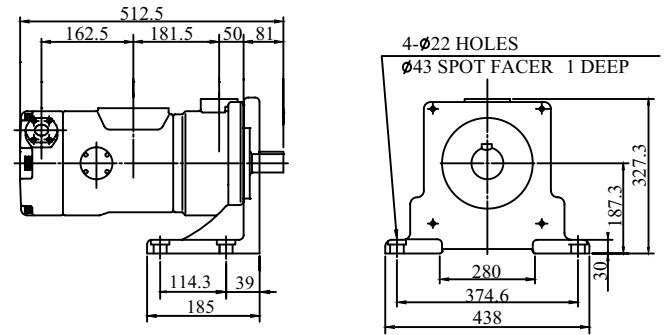
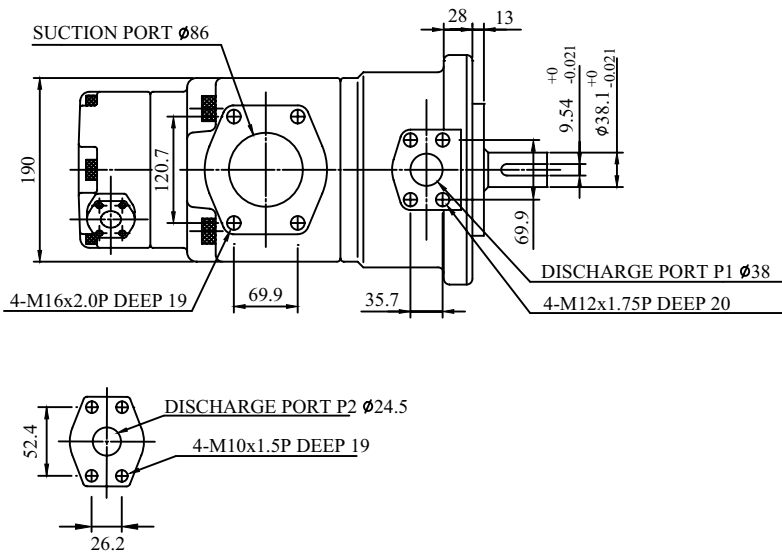

Foot Type (腳座型)

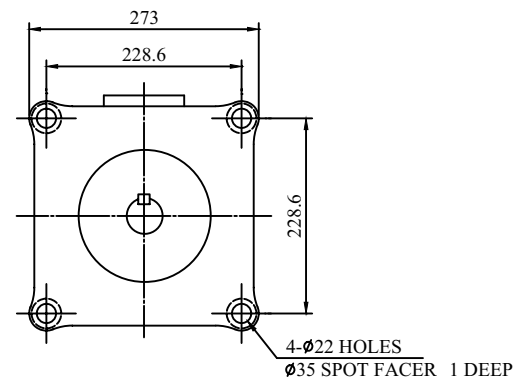
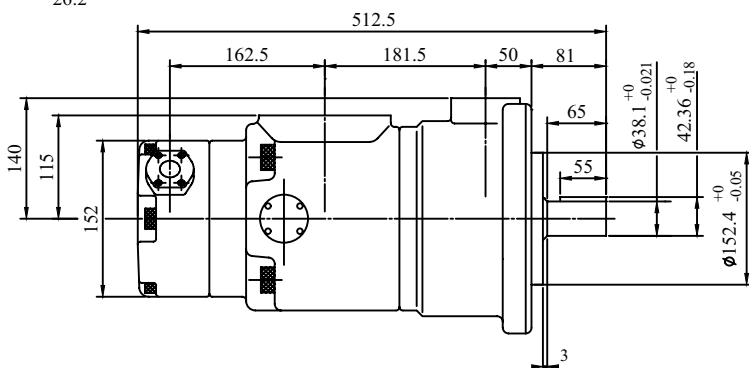

VQ435

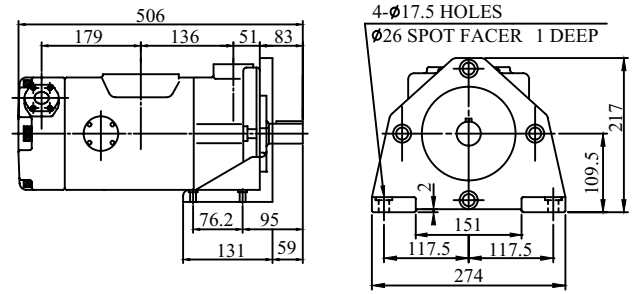
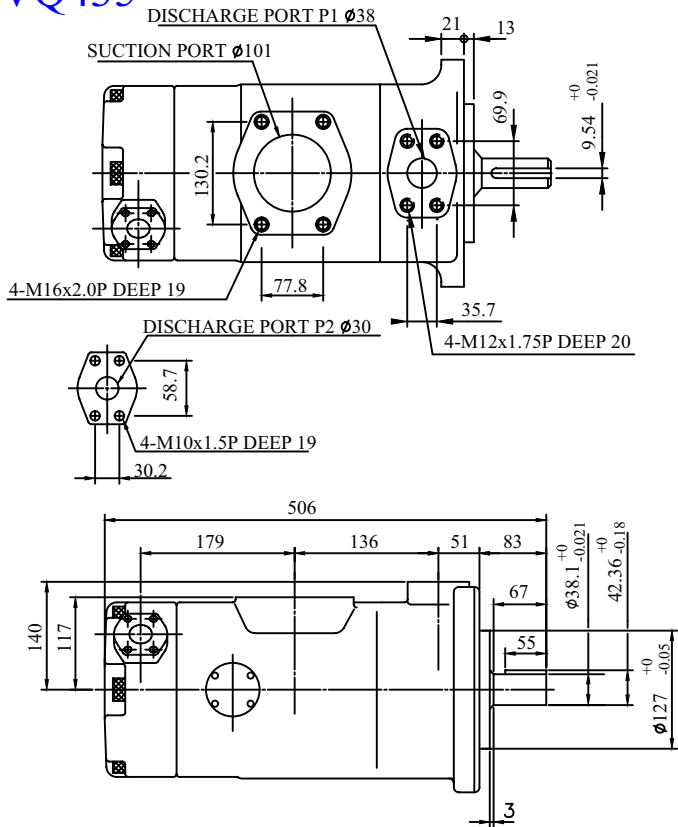

Foot Type (腳座型)

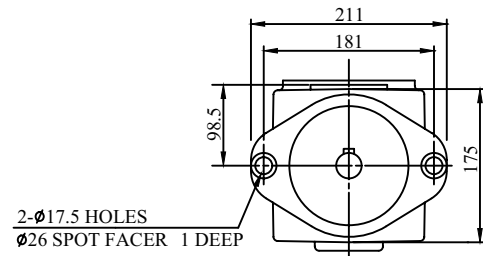

DVQ435

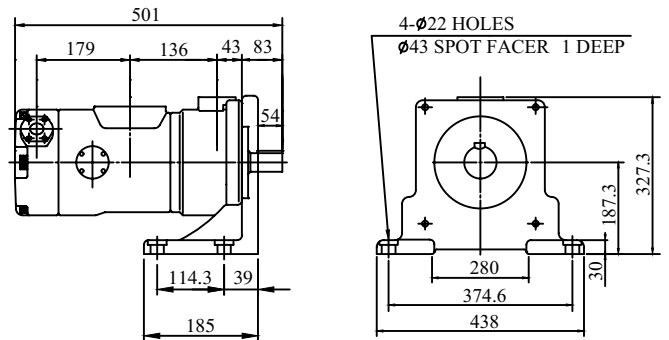
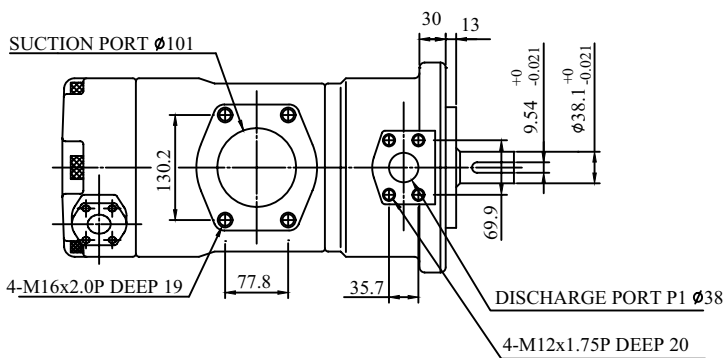

Foot Type (腳座型)

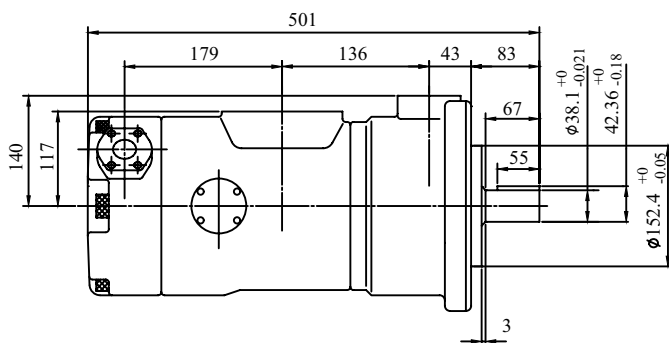

4- $\phi 22$ HOLES
 $\phi 35$ SPOT FACER 1 DEEP

SVQ435

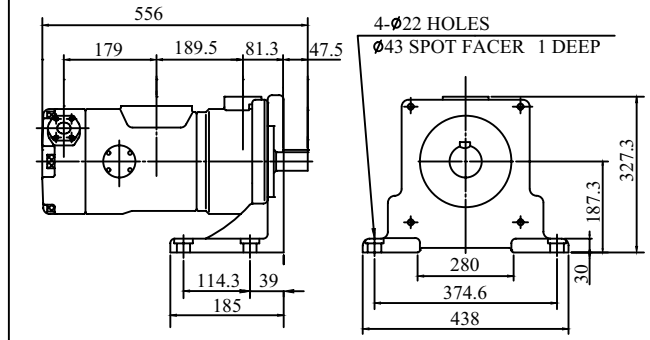
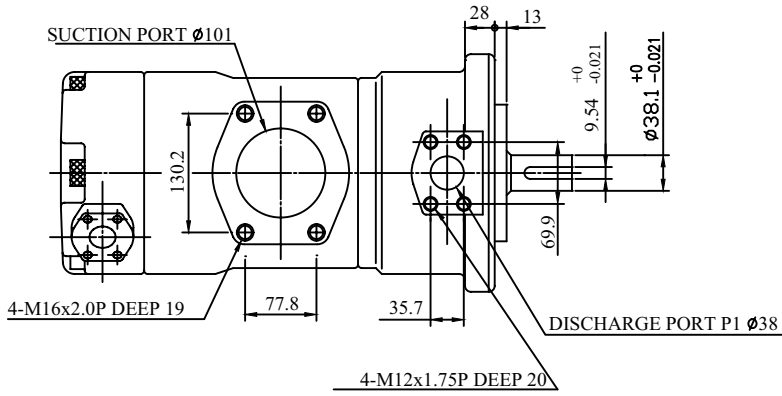

Foot Type (腳座型)

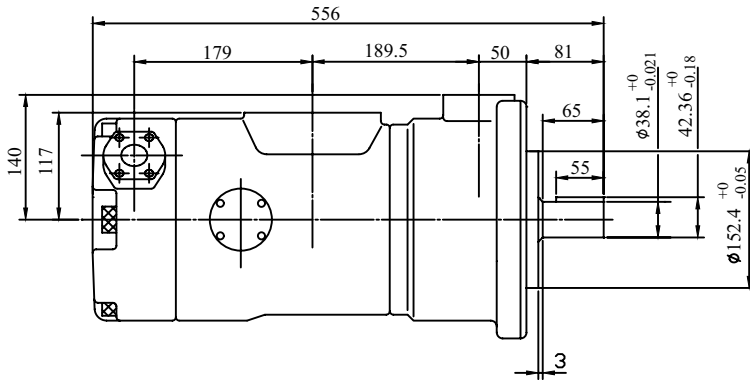
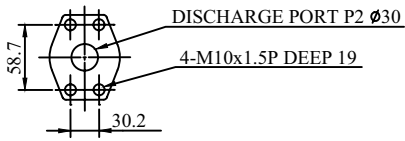

4- $\phi 22$ HOLES
 $\phi 35$ SPOT FACER 1 DEEP

